

RO INSTRUCTIUNI DE ASAMBLARE - **CORP SUPERIOR 2USI STICLA** - 80 x 30 x 60 CM

EN ASSEMBLY INSTRUCTIONS - **SUPERIOR CABINETT 2 DOORS WITH GLASS** - 80 x 30 x 60 CM

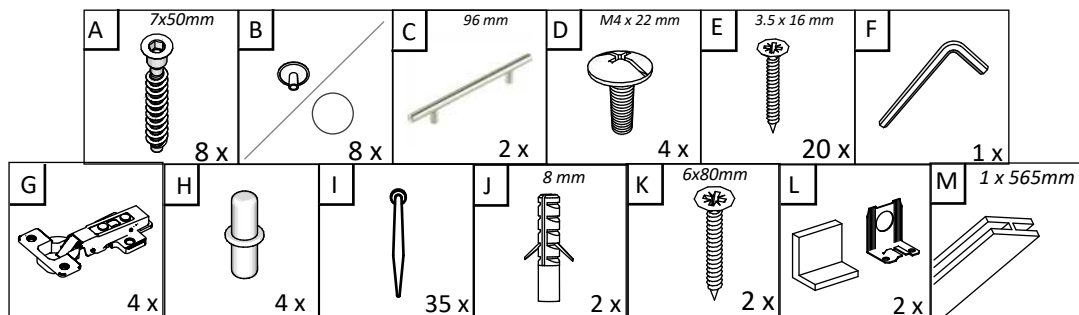

No	B	b	x
1	600	280	1
2	600	280	1
3	768	280	2
4	768	270	1
5	596	396	2
6	596	396	2

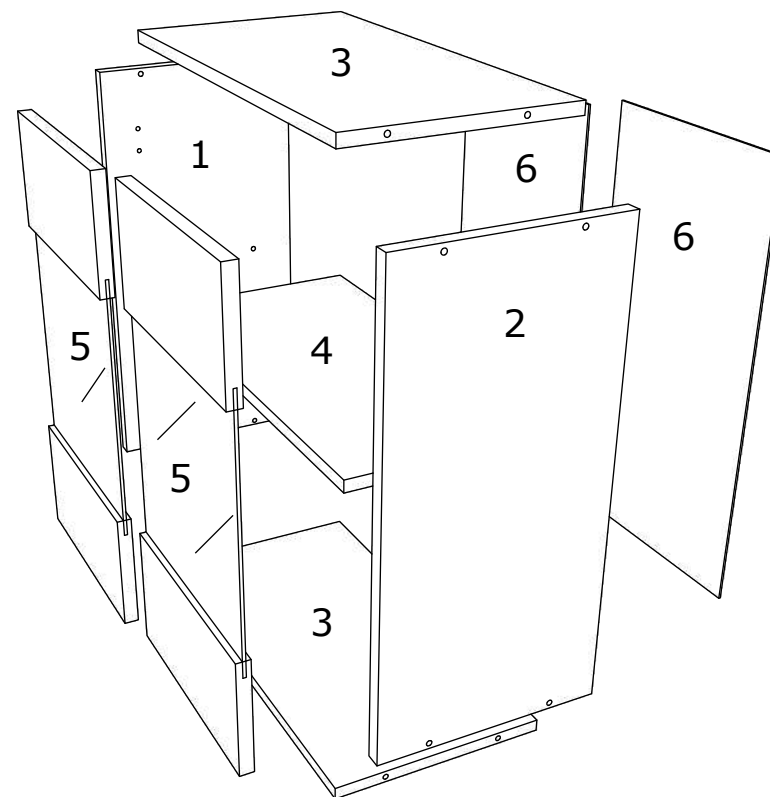
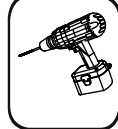
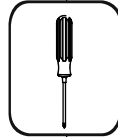
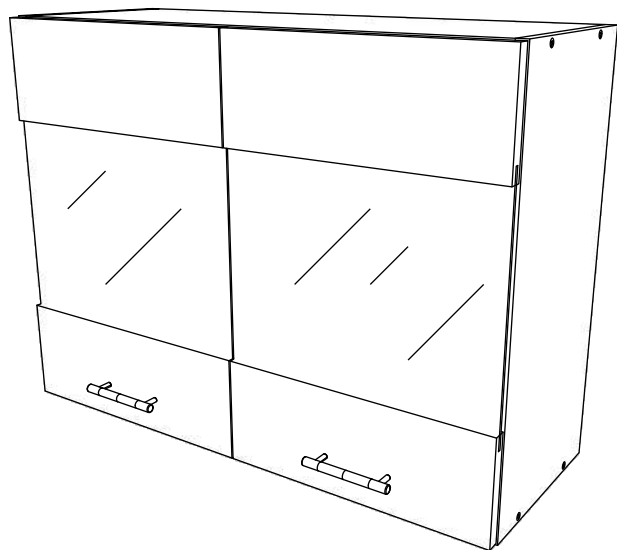
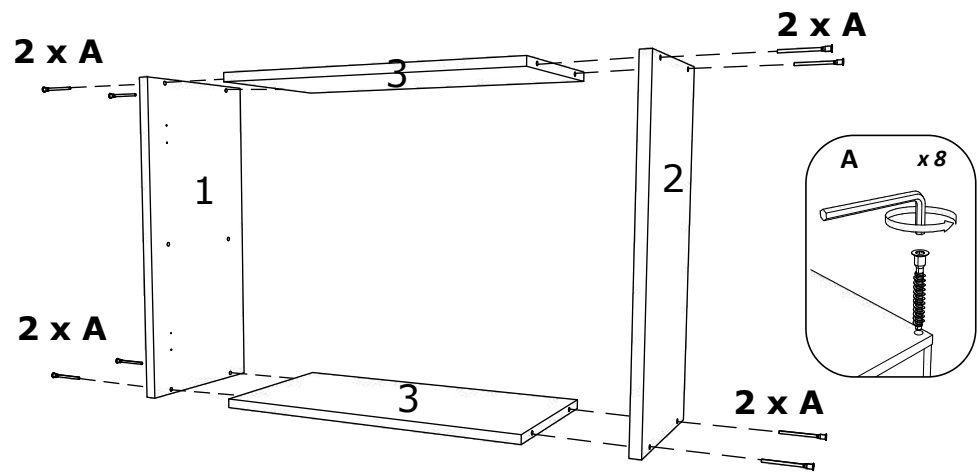

1

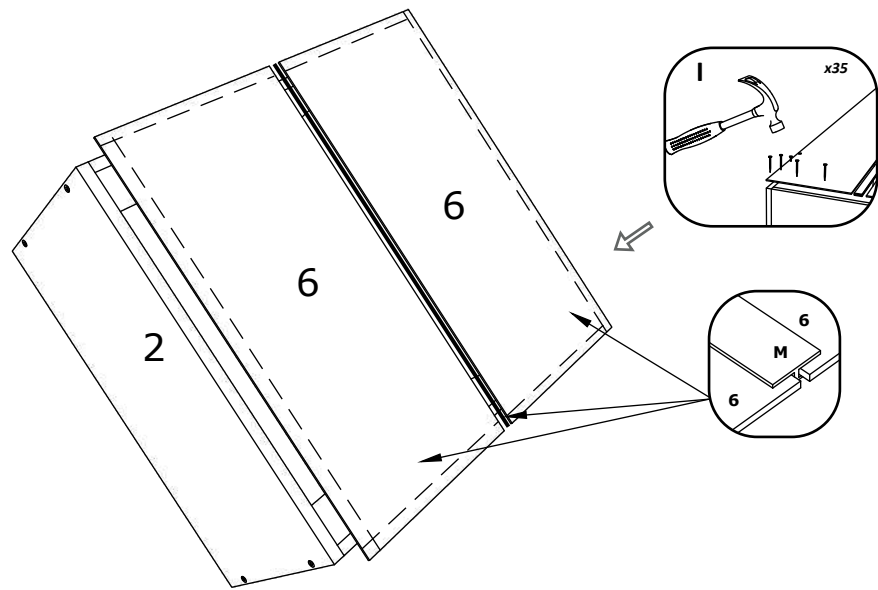

2

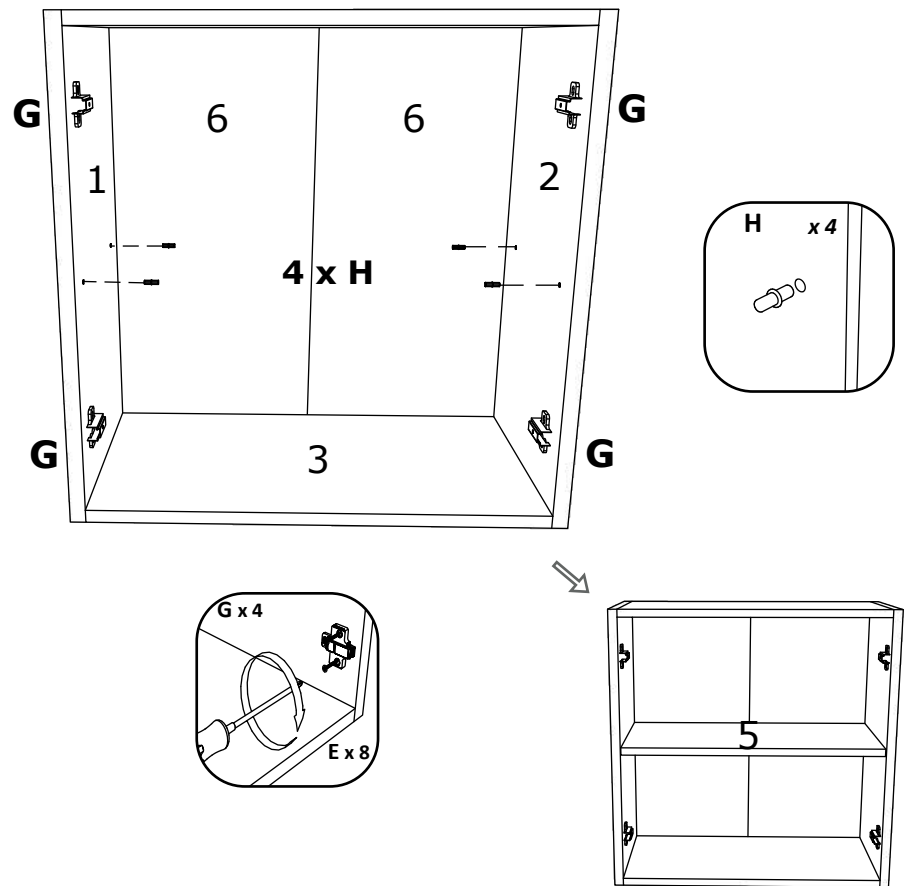

3

